



**DecoForme**<sup>TM</sup>  
Decorative Battens

# DecoForme™

## Decorative Battens

Made from an E-Zero moisture-resistant MDF substrate and wrapped in decorative overlay, DecoForme™ pre-finished decorative battens impart the warmth and character of timber, providing a durable and cost-effective solution.

DecoForme™ provides a warm and rich textured appearance for a wide variety of panelling, ideal for wall and ceiling applications in either a vertical or horizontal set out, creating strong directional lines that will add a striking feature to any internal space.

### Typical Uses

Uses include but not limited to:

- Feature walls and ceilings
- Room dividers
- Kitchen bar fronts
- Reception counters
- Stairwells
- Home Front Entry features
- Headboards and Furniture

### Features

- A pre-finished product with no further finishing work required
- Ready to fabricate and assemble
- Supplied in COC, PEFC, Responsible Wood and Green Tag Level A certified MR MDF E-Zero substrate
- Selected colours are also available in matching low pressure laminate and internal doors
- Group 3 fire rating – AS/NZS 3837:1998, ISO 5660-1:2015

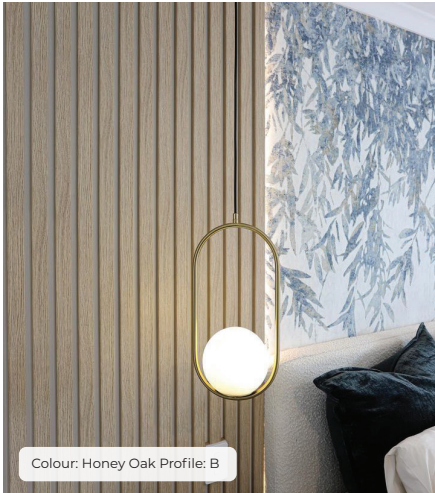

Colour: Honey Oak Profile: B

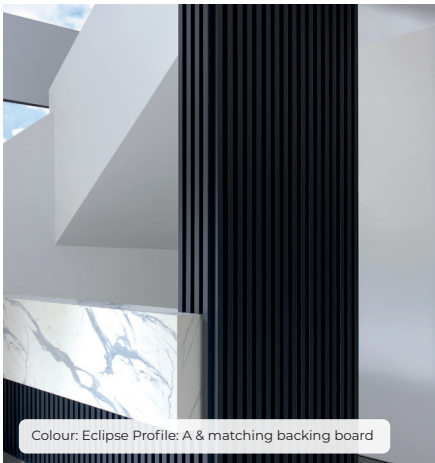

Colour: Eclipse Profile: A & matching backing board



Colour: Honey Oak Profiles: A, D, E

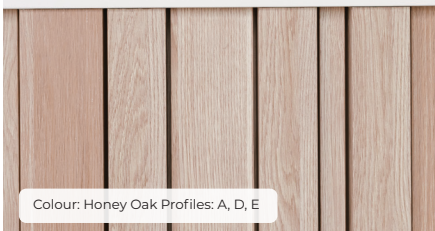

# The DecoForme Range

All colours are supplied in a 3600mm length and available in the following dimensions:

## Standard Profiles:

- A. 31mm x 31mm
- B. 17mm x 38mm
- C. 31mm x 65mm
- D. 50mm x 70mm
- E. 50mm x 100mm

## Half Round Profiles:

- F: 17mm x 34mm
- G: 24mm x 48mm
- H: 31mm x 62mm

## Cove Profile:

- I: 17x34mm

Matching edge tape available.  
 Matching melamine backing sheets available in 3115 x 1200 x 16mm size.

DecoForme End Profiles (mm)

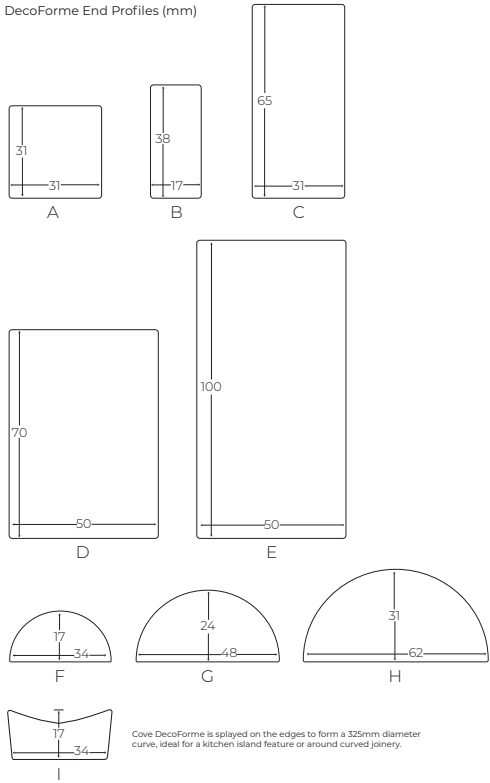

Colour: Sahara Profile: I



Colour: Eclipse Profile: F



Honey Oak

Snowfall

Bianca

Lunar

Raw

Sahara

Woodland

Fossil

Tuscany

Storm

Savanna

Eclipse

Onyx

## PROFILE AVAILABILITY

	STANDARD						HALF ROUND			COVE
	A 31 x 31mm	B 17 x 38mm	C 31 x 65mm	D 50 x 70mm	E 50 x 100mm	F 17 x 34mm	G 24 x 48mm	H 31 x 62mm	I 17 x 34mm	
<i>Supplied in lengths of 3600mm</i>										
<i>Minimum order quantities of 15 battens per colour apply, with the exception of our stocked products marked No Min</i>										
<i>Leadtime on non stocked profiles: Allow 6 weeks. Check availability</i>										
Raw MDF	n/a	n/a	n/a	n/a	n/a	No Min	No Min	15	15	
Honey Oak	No Min	No Min	No Min	No Min	No Min	No Min	No Min	15	No Min	
Snowfall	15	15	15	15	15	No Min	15	15	15	
Fossil	No Min	No Min	15	15	15	15	15	15	15	
Eclipse	No Min	No Min	No Min	15	15	No Min	No Min	15	15	
Savanna	No Min	15	15	15	15	No Min	15	15	15	
Sahara	No Min	No Min	No Min	15	No Min	No Min	No Min	15	No Min	
Storm	15	15	15	15	15	No Min	15	15	15	
Woodland	No Min	No Min	15	15	15	No Min	15	15	15	
NEW Tuscany	15	15	15	15	15	15	15	15	15	
NEW Bianca	15	15	15	15	15	15	15	15	15	
NEW Lunar	15	15	15	15	15	15	15	15	15	
NEW Onyx	15	15	15	15	15	15	15	15	15	

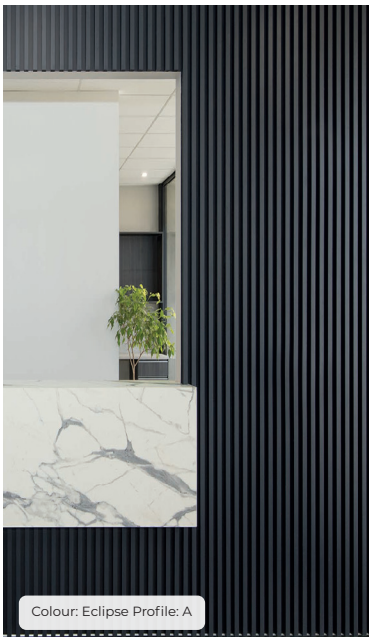

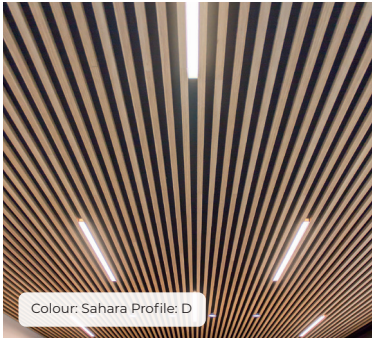

Colour: Sahara Profile: D

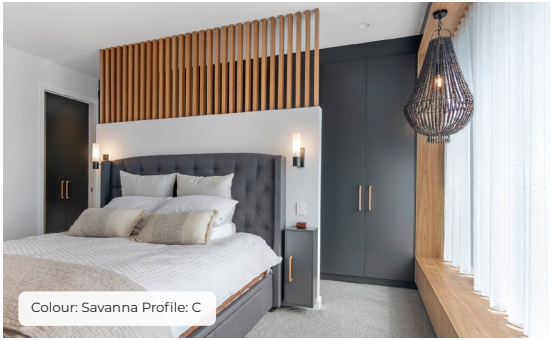

Colour: Savanna Profile: C



Colour: Honey Oak Profiles: A, D, E

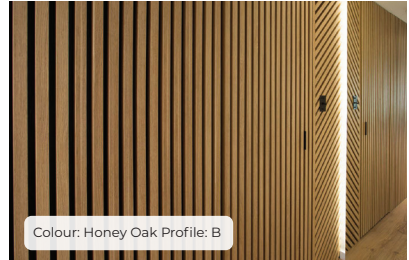

Colour: Honey Oak Profile: B



Colour: Snowfall Profile: H

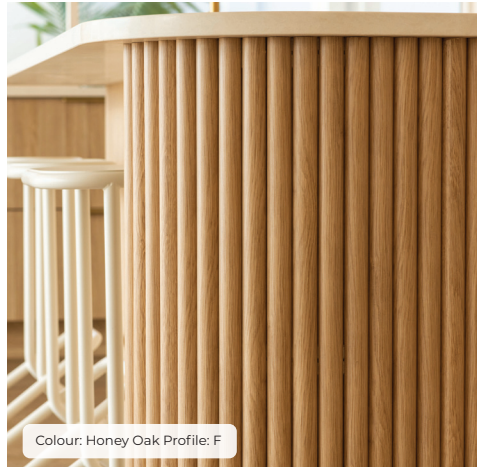

Colour: Honey Oak Profile: F

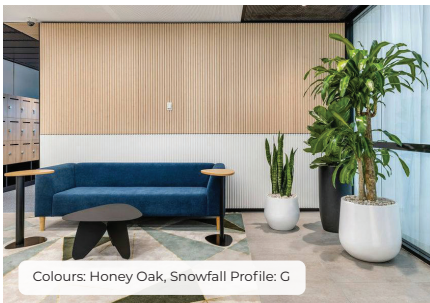

Colours: Honey Oak, Snowfall Profile: G



Colour: Honey Oak Profile: B



Colour: Honey Oak Profile: F



Colour: Honey Oak Profile: B

## Fixing and Installation

DecoForme™ Decorative Battens are designed to be easily cut and installed by any joiner, builder or weekend warrior. The MR MDF substrate is easily cut using standard wood working machinery such as a drop saw. Ensure you have a sharp fine finishing blade.

DecoForme™ Decorative Battens are purely a decorative product and therefore the applications are wide and varied.

Impress Panels does not offer a proprietary fixing system for DecoForme™ Decorative Battens however, subject to your specific application, there are many fixing possibilities and commercially available systems. It is up to the installer to ensure that all fixing and installation is fit for purpose. Fixing methods differ depending on application, but typical installations include:

- Screw fix from the back of a panel then install the panel to the wall
- Glue fix – we recommend Gorilla FixAll High Tack Adhesive. Use Scotch Extremely Strong Mounting Tape to hold DecoForme™ in place while glue sets
- Dowel inserts each end for free standing vertical installations
- Concealed fixing options are available for applications such as suspended ceilings. Hafele Striplox Pro 23, these can also be purchased through Impress Panels.



Hafele Striplox Pro 23

Visit [www.decoforme.co.nz](http://www.decoforme.co.nz) to download our Installation & Fixing Guide.

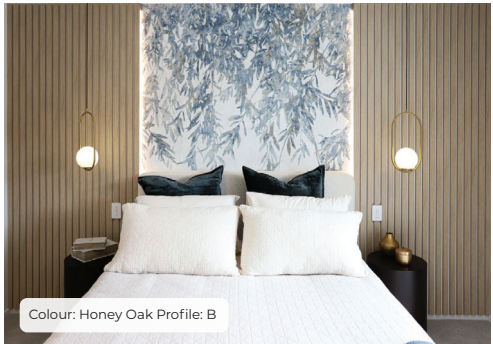

**Limitations & Design Considerations**

- DecoForme™ Decorative Battens are a non-structural product developed for decorative purposes only.
- Strictly for internal use, not for use in exterior applications including alfresco areas.
- Should not be used in wet areas such as bathrooms or environments of high humidity.
- Can be cut to length, however should not be cut in a lineal direction. It is recommended to protect cut edges from moisture ingress by either using a clear sealer or by applying edge tape.
- Where DecoForme™ Decorative Battens may be susceptible to high traffic flow, quality or appearance may be impaired.
- Wet mopping and vacuum cleaners may cause damage to DecoForme™ Decorative Battens at floor level. Consider incorporating a minimum 50mm clearance between the floor and the batten.

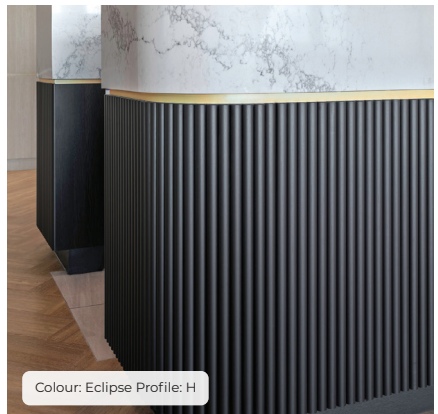

DecoForme™ is marketed and distributed by Impress Panels Ltd.

p 03 929 5641

e sales@impresspanels.co.nz

w decoforme.co.nz